

TP01

Thermal properties sensor

TP01 is the leading sensor for long-term monitoring of soil thermal conductivity. A measurement with TP01 may also be used to estimate soil thermal diffusivity and volumic heat capacity, leading to a better understanding of dynamic (variable heat flux) thermal behaviour of soils. TP01 is designed for long-term use at one measurement location. Applied in meteorological surface flux measurement systems, TP01 improves the estimates of heat transport in the soil and of the so-called storage term.

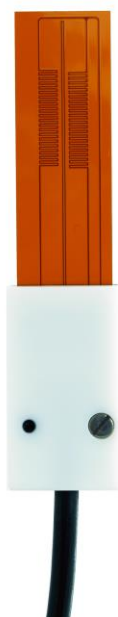

Figure 1 TP01 thermal properties sensor



Figure 2 TP01 is typically used in high-accuracy surface flux measurement stations

Introduction

TP01 measures soil thermal conductivity. It is designed for long-term on-site operation, buried in the soil. Its rated operating range is 0.3 to 4 W/(m·K), which covers most inorganic soil types.

The sensor inside TP01 is a temperature-difference sensor consisting of 2 thermopiles. It measures the radial temperature difference around a heating wire with a record breaking sensitivity. Both the heating wire and the sensor are incorporated in a very thin plastic foil. It can be connected directly to commonly used data logging systems. The low thermal mass of TP01 also makes it suitable for measuring the thermal diffusivity.

TP01 should be incorporated in the user's measurement and control system. Typically every 6 hours, the TP01 heater is switched on to perform a measurement. The thermal conductivity, λ , is calculated by dividing the TP01 sensitivity, S , by the sensor output, a small voltage difference ΔU which is a response to stepwise heating, and multiplying by the applied electrical power Q per meter heating wire.

The measurement function of TP01 is:

$$\lambda = S \cdot Q / U \quad (\text{Formula 0.1})$$

The factory-determined sensitivity S , as obtained under calibration reference conditions, is provided with TP01 on its product certificate.

Thermal diffusivity and volumic heat capacity are estimated from the time response to stepwise heating. These measurements are optional. The volumic heat capacity is a linear function of soil water content and TP01 may be employed to monitor trends in soil water content.

Contrary to many other soil water content sensors, TP01 is not sensitive to contamination by salts and the measurement still functions in electrically conducting saline or fertilised soils.

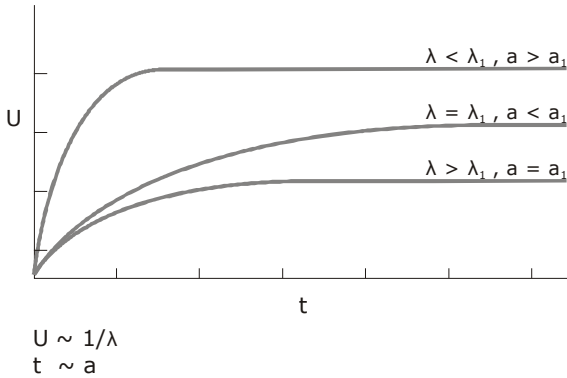

Figure 3 TP01 signal in different soil types: the signal amplitude varies with $[1/\lambda]$, the response time varies with thermal diffusivity $[a]$

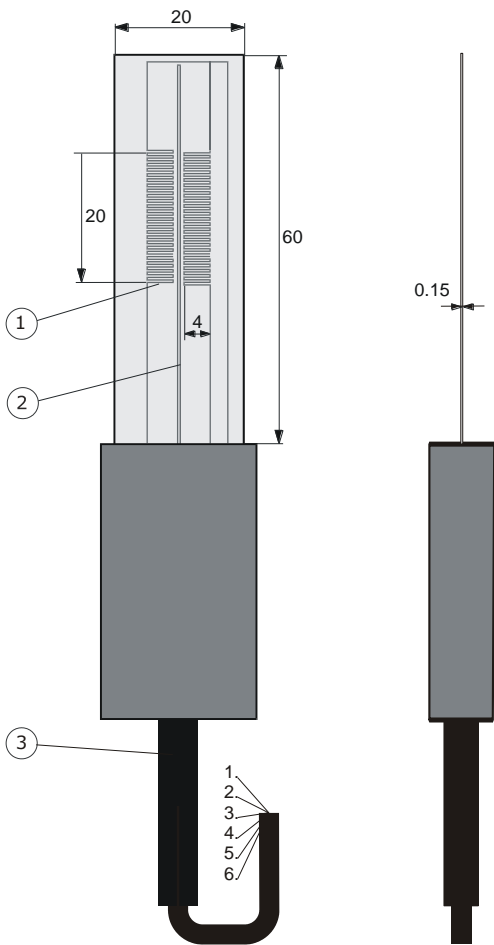

Figure 4 TP01: (1) thermopile sensor, (2) heating wire, (3) cable. Dimensions in $\times 10^{-3}$ m.

TP01 specifications

Measurand	thermal conductivity
Optional non-traceable measurands	-thermal diffusivity -volumic heat capacity
Optional trend monitoring	soil water content
Rated operating environment	surrounded by soil
Rated measurement range	0.3 to 5 W/(m·K)
Rated operating temperature range	-30 to +80 °C
Sensor foil thickness	0.15×10^{-3} m
Interval between measurements	6 hr (typical), optionally 3 to 12 hr
Duration of measurement	360 s
Heating interval duration	180 s
Heater rated power supply	1 to 2 VDC, < 0.4 A
Power consumption	
daily average	0.007 W
Standard cable length	5 m
Measuring system requirements:	
Required readout and control	2 x differential voltage 1 x switchable power
Required uncertainty (k = 2)	10×10^{-6} V at 10^{-3} V 5×10^{-3} V at 2 V
Order code	TP01/cable length in m

Options

- longer cable, in multiples of 5 m, cable lengths above 20 m in multiples of 10 m

Suggested use

A typical TP01 is part of a meteorological surface flux measurement system in which also wind, humidity, soil heat flux, soil temperatures at different depths and net radiation are measured. TP01 then serves to improve the estimate of the so-called storage term, which is used to model thermal heat transport in the soil.

Measurements with TP01 are often combined with soil temperature profile measurements with sensor model **STP01** and measurements with heat flux sensor model **HFP01SC**.

Soil thermal properties change as a function of depth, in particular close to the soil surface. A typical measurement location is equipped with sensors at several depths. For good spatial averaging at least 2 sensors (> 5 m apart) should be installed at every depth.



Figure 5 STP01 soil temperature profile sensor which is often combined with TP01 for soil energy budget calculation.

Hukseflux has equipped several testbeds in the electrical power industry, to monitor dryout, thermal runaway and thermal stability around mockup high-voltage power lines. Here the capability to perform a crude measurement of thermal diffusivity is an important feature, for modelling behavior under dynamic loads.

Calibration & performance assessment

The performance of a TP01 measuring system can be verified using glycerol or agar gel as calibration reference material.

See also

- STP01 soil temperature profile sensor
- for laboratory use, models TP02 and TP08 are available. Turn key measuring systems are TPSYS02, FTN02 and MTN02.
- Hukseflux sensors for surface flux measurement
- heat flux sensors HFP01 and HFP01SC

About Hukseflux

Hukseflux Thermal Sensors offers measurement solutions for the most challenging applications. We design and supply sensors as well as test & measuring systems, and offer related services such as engineering and consultancy. With our laboratory facilities, we provide testing services including material characterisation and calibration. Our main area of expertise is measurement of heat transfer and thermal quantities such as solar radiation, heat flux and thermal conductivity. Hukseflux is ISO 9001:2008 certified. Hukseflux sensors, systems and services are offered worldwide via our office in Delft, the Netherlands and local distributors.

Interested in this product?
E-mail us at: info@huksefluxusa.com